

# Enhancement of the steel quenching process by an electric field

K. J. CHENG, G. W. PEARSALL, J. B. CHADDOCK

*Department of Mechanical Engineering and Materials Science, Duke University, Durham, North Carolina 27706, USA*

An electric field is known to be able to increase considerably the heat flux during the boiling process by suppressing the occurrence of film boiling. This field enhancement technique can be applied to the steel quenching process to accelerate the cooling rate and thus increase the effective hardenability of the steel. This report describes a quench experiment performed with an electric field. The effective hardenability (depth of high hardness) of the samples quenched with the field was measured to be significantly higher than those quenched without the field. Examination of the microstructures showed that the application of the electric field increased the depth to which martensite formed in the sample.

## 1. Introduction

The quality of a steel quenching process depends on the intrinsic (alloy-controlled) hardenability of the steel and the heat transfer rate during the quench. A successful quench is one that develops substantial martensite in the sample with a minimum amount of cracking. Achieving this result requires a careful choice of the steel, the quenching liquid, and the quench conditions. For economic reasons, it is desirable to use the steel with lowest alloy content to obtain the required hardness and hardenability. Thus the cooling capacity of the quenching liquid is of vital importance to the quench.

An ideal cooling rate for a quench is one that is fast in the high-temperature range where austenite decomposes easily into ferrite and iron carbide, and slow in the low-temperature range where austenite transforms into martensite. A rapid cooling rate in the high-temperature range suppresses the formation of ferrite and iron carbide and thereby increases the formation of martensite at lower temperatures; a slow cooling rate in the low-temperature range minimizes thermal stresses and suppresses quench cracking. Unfortunately, nature is mischievous enough to bestow upon boiling liquids the opposite cooling rate: slow at high temperatures because of film boiling and fast at low temperatures because of nucleate boiling. The saga of heat-treating steel can be said to be a long struggle against this boiling behaviour.

This report describes a method to modulate the cooling rate of a quench by means of an electric field. Our experimental data suggest that it is a promising way to enhance the quenching process. The use of electrical effects to enhance the quenching process was first reported by Sedgwick in 1889 in a US Patent [1]. However, Sedgwick incorrectly attributed the enhancement of the quench to the "passage of electric current" through the sample, rather than to the action of the electric field on the boiling heat transfer process during the quench. Thus he failed to disclose the

proper procedures to perform the electric field enhanced quenching process, and his patent seems to have received little attention. The use of an electric field to enhance the quenching process was first demonstrated and disclosed properly by Skimbov *et al.* [2]. However, their experiment was done with an extremely strong electric field ( $270 \text{ kV cm}^{-1}$ ) in which insulation against dielectric breakdown can become a serious problem. This raises concern for the feasibility of the process in real applications. Our experiment suggests that significant improvement in quench quality can be obtained with a moderate electric field strength of about  $10 \text{ kV cm}^{-1}$ , and shows that the process is indeed a practical one.

## 2. Effects of an electric field on heat transfer during a quench

Numerous experimental and theoretical studies [3-7] over the last two decades have demonstrated that an electric field can increase significantly the boiling heat flux of a dielectric liquid. This electric field effect on boiling can be illustrated by a schematic boiling curve, which is a plot of the surface heat flux as a function of the temperature difference (between the temperature of the heating surface and the boiling point of the liquid), as shown in Fig. 1. The ordinary boiling process in the absence of an electric field (lowest curve of Fig. 1) may be divided loosely into three regimes: AB, nucleate boiling; BC, transition boiling; and CD, film boiling. Nucleate boiling is characterized by the periodic formation and growth of individual bubbles from the heating surface and their subsequent departure into the bulk of the liquid due to buoyancy force. As the temperature of the heating surface increases, more bubble formation sites are activated, and the bubble growth and departure processes accordingly take place increasingly faster. If the temperature of the heating surface continues to rise, eventually the boiling process will become so intensive that the bubbles coalesce to form an insulating vapour blanket on the

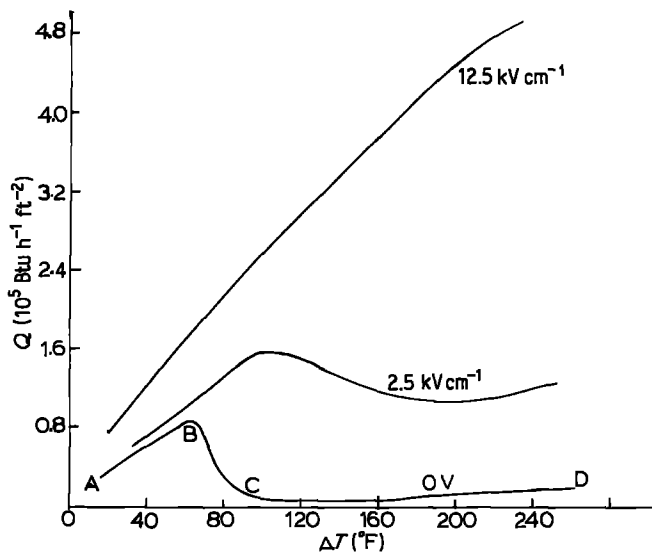

Figure 1 Boiling curve of isopropanol with and without an electric field. AB = nucleate boiling, BC = transition boiling, CD = film boiling. Figure is adapted from [3].

heating surface. This is the onset of film boiling. The insulating vapour blanket accounts for the very low heat transfer rate during boiling at high temperatures, and is a nuisance in the quenching process.

The purpose of applying an electric field to the quenching process is to suppress the formation of the vapour blanket (see [4] for a description of the mechanism of this process). Fig. 1 shows that in the presence of an electric field, film boiling is suppressed and the heat transfer rate in the high-temperature range can be increased by almost an order of magnitude. On the other hand, the electric field effect on the ordinary nucleate boiling regime is minimal compared to that on the film boiling regime. Thus the application of an electric field to the quenching process potentially can change the cooling rate towards the ideal one, which is fast at high temperatures and slow at low temperatures.

### 3. Apparatus and experimental procedure

In order to investigate the electric field effects on the quenching process, an experiment was designed in which cylindrical steel samples were quenched in oil in the presence of a cylindrical electric field, as shown in Fig. 2.

The mechanical design of the experiment is shown in Fig. 3. The apparatus consists of five major components: (i) a four-legged stand, (ii) an electric furnace, (iii) a cylindrical beaker (inner diameter = 6 cm, capacity = 1 litre), (iv) a guiding tube, and (v) a high voltage supply.

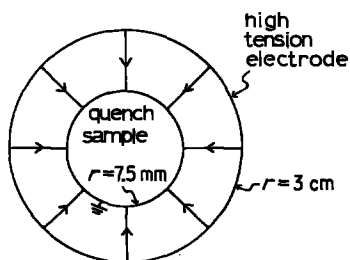

Figure 2 Geometry of electric field in quench experiment.

The quench sample was suspended from a long wire and a metal stopper was securely fastened to the mid-section of the wire. The sample was heated in the furnace with the stopper resting on the upper platform of the four-legged stand. When the stopper was pushed off the upper platform, the sample then fell into the quench bath. The position of the stopper on the wire was adjusted so that when the stopper was resting on the upper platform, the quench sample was suspended inside the furnace; and when the stopper was resting on the lower platform, the sample was at the desired depth inside the quench liquid. In addition to suspending the sample, the wire also provided the electrical connection from the ground terminal of the high voltage source to the sample. Bicycle transmission wire was used because it has a size and flexibility particularly suitable for this experiment. The wire was replaced after every four runs, because the high temperature in the furnace weakened the wire with time.

The interior surface of the upper part of the quench beaker was sheathed with a sheet of aluminium. This metal sheet was connected to the high tension terminal

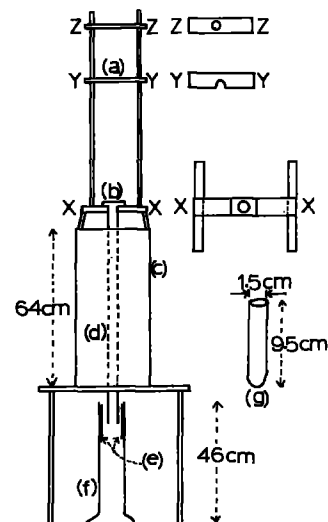

Figure 3 Mechanical design of quench experiment. (a) upper platform of stand, (b) lower platform of stand, (c) electric furnace, (d) guiding tube, (e) high tension electrode, (f) quench bath, (g) quench sample.

TABLE I Compositions of steel samples. Data source: private communication from Joe Stravinkas of Bethlehem Steel Corporation.

	C	Mn	P	S	Si	Cu	Ni	Cr	Mo
1045	0.47	0.83	0.08	0.02	0.23	0.14	0.06	0.06	0.02
1035	0.33	0.82	0.02	0.03	0.25	0.05	0.03	0.04	0.01

of the voltage source and served as the high voltage electrode. The quench sample, being electrically connected to the ground terminal of the voltage source, was the ground electrode. These two electrodes provided the cylindrical electric field in the quenching liquid. The surface of the aluminium sheet facing the liquid was coated with an insulating layer of urethane varnish to reduce the possibility of electric discharge when a high voltage was applied.

The samples were 1045 and 1035-steel, and their compositions are shown in Table I. Two different quench oils were used: DURO AW16 (manufactured by Sinclair) and Sunquench 1032. Some of the properties of Sunquench 1032 are tabulated in Table II.

In each experiment, the furnace was first preheated for about 45 min with the thermostat set at 843°C. The sample was then heated in the furnace in atmospheric air for about 30 min and subsequently released to the quenching bath. The guiding tube ensured that the sample entered the quenching liquid at the centre of the bath. This is important in the experiments when the electric field was applied, because cylindrical symmetry is required for a uniform field, and furthermore, if the sample (being the ground electrode) touched the aluminium high voltage electrode, a spark would be likely to occur.

The samples were quenched in pairs, one with an electric field and another without the electric field. This was done so that the effect of the electric field on the quench quality could be seen while all other experimental conditions were kept constant.

#### 4. Experimental results

Figs 4 to 7 show the hardness profiles of four pairs of quenched samples. Each data point is the average of three independent hardness readings taken along different radii on the same cross section of the sample. In each case, the cross section examined is about 3 cm from the top of the sample.

TABLE II Manufacturer's specifications for SUNQUENCH 1032

	Premium Sunquench 1032
Viscosity, SUS/100°F	94.0
API gravity, 60°F	32.9
Flash point, COC (°F)	355
Hot wire (A)	39
5 sec heat removal (%)*	30
Quenchometer (sec)	
Nickel ball	10.0
Chromized ball	13.0

\*Heat removed from a 250 g piece of stainless steel heated to 1575°F and quenched in 3 litres of oil in a 4 litre Labline Thermocup.

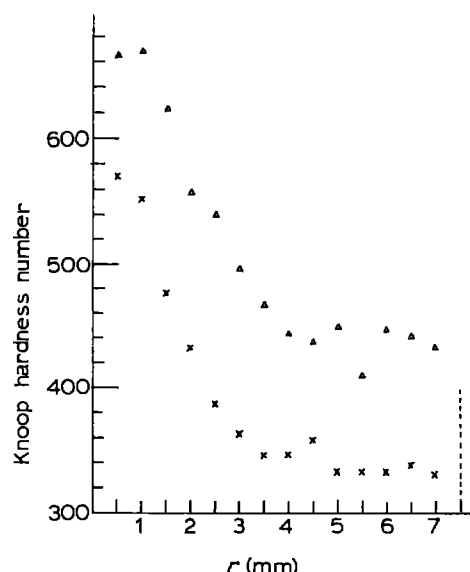

Figure 4 Hardness profiles of 1045 steel samples quenched in DURO AW 16. (x) zero field, (Δ)  $V_0 = 12$  kV,  $r$  = radial distance measured from the surface, (---) centre line of sample.

The voltage across the electrodes,  $V_0$ , can be converted into the electric field strength ( $E$ ) at the sample surface approximately using the formula:

$$E = \frac{V_0}{r_1} \frac{1}{\ln(r_2/r_1)}$$

where  $r_1$  (= 0.75 cm) and  $r_2$  (= 3 cm) are the radius of the sample and internal radius of the quench bath, respectively. The conversion is only approximate because the formula is derived for two concentric cylinders, but the simplicity of the apparatus cannot ensure that the sample and the quench bath are exactly concentric.

The hardness profiles indicate that the hardness of the samples can be increased significantly by merely applying an electric field while keeping the quenching liquid and other quenching conditions the same. The data also show that for the 1045 samples, the most significant improvement in hardness occurs at the interior of the sample; whereas for the 1035 samples the improvement occurs mostly near the surface.

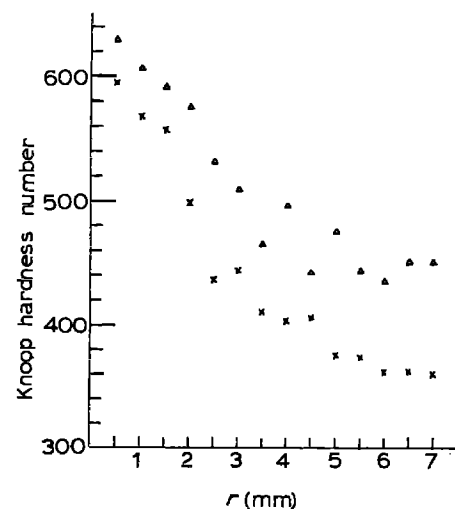

Figure 5 Hardness profiles of 1045 steel samples quenched in SUNQUENCH 1032. (x) zero field, (Δ)  $V_0 = 12$  kV.

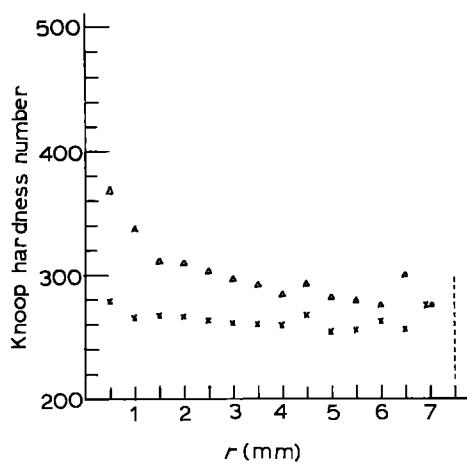

Figure 6 Hardness profiles of 1035 steel samples quenched in DURO AW 16. (x) zero field, ( $\Delta$ )  $V_0 = 11$  kV.

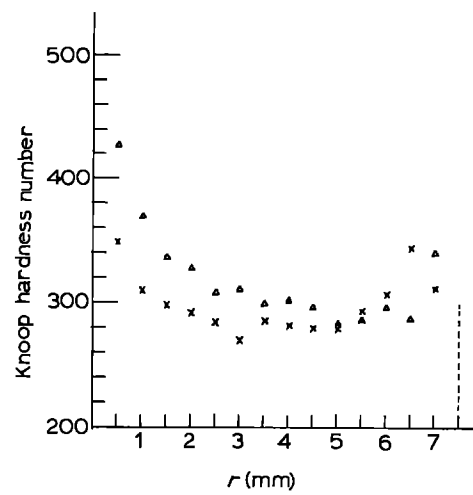

Figure 7 Hardness profiles of 1035 steel samples quenched in SUNQUENCH 1032. (x) zero field, ( $\Delta$ )  $V_0 = 12$  kV.

(More hardness data from this experiment can be found in [4]).

Figs 8 and 9 show the microstructures near the surfaces and the centres of the two 1045 steel samples, the hardness profiles of which are plotted in Fig. 5. It is seen that the sample quenched with the electric field contains a higher proportion of martensite, both near the surface and near the centre. This higher proportion of martensite correlates with the difference in hardness between the two sets of data points in Fig. 5. This steel exhibited moderate, persistent banding in the normalized condition, and this inhomogeneity probably accounts for the variance shown by the hardness profiles in Figs 4 and 5; however, the effects of this inhomogeneity are insignificant compared to the effect of the electric field.

Figs 10 and 11 show the microstructures near the surfaces and the centres of the two 1035 steel samples, the hardness profiles of which are plotted in Fig. 6. This steel appeared to possess a very fine prior-austenite grain size, making it somewhat more difficult to positively identify each microconstituent, especially in small regions. The hardness evidence certainly supports the hypothesis that the electric field suppressed the formation of pearlite and ferrite by increasing the

heat transfer rate in the high-temperature regime, thereby facilitating the transformation from austenite to martensite in the low-temperature regime. The microstructures of the sample quenched with the electric field do contain a higher proportion of martensite, especially near the surface, as would be expected from the hardness profiles. As with the 1045 steel, this 1035 steel also exhibited moderate, persistent banding in the normalized condition, which probably accounts for the hardness-profile variance in Figs 6 and 7.

## 5. Advantages and restrictions of using an electric field to modulate the quenching process

The main advantage of using an electric field to modulate the quenching process is that it has an infinite potential flexibility. The cooling rate during the quench is dependent on the electric field strength, which can be set to a desired value by simply turning the knob of the voltage supply.

This electric-field modulated quenching process can be developed further to a microprocessor-controlled quenching process. Once the relation between the cooling rate and the applied field strength is understood sufficiently well, one could design a microprocessor-

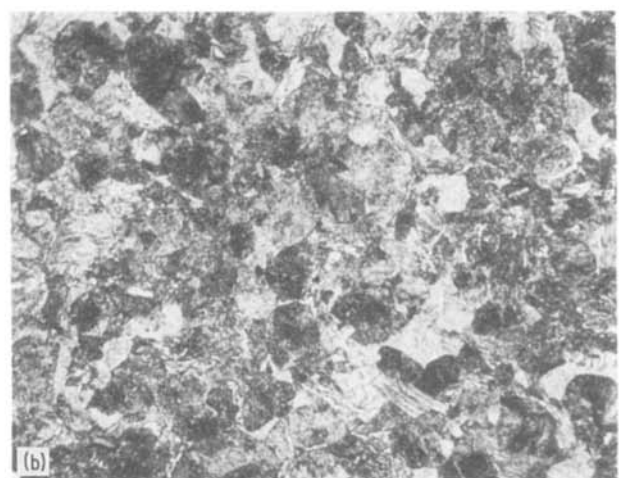
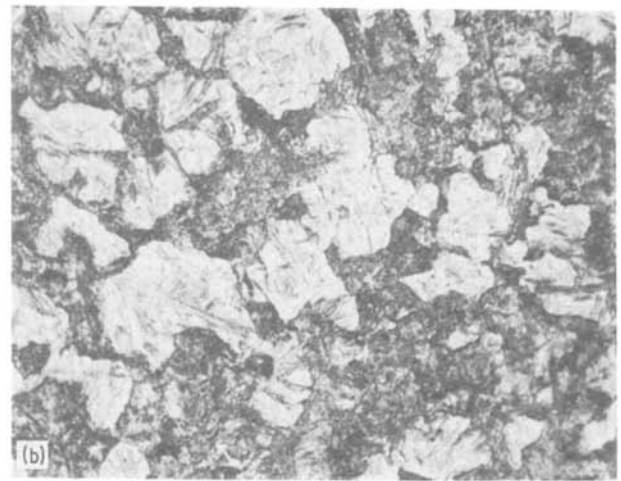
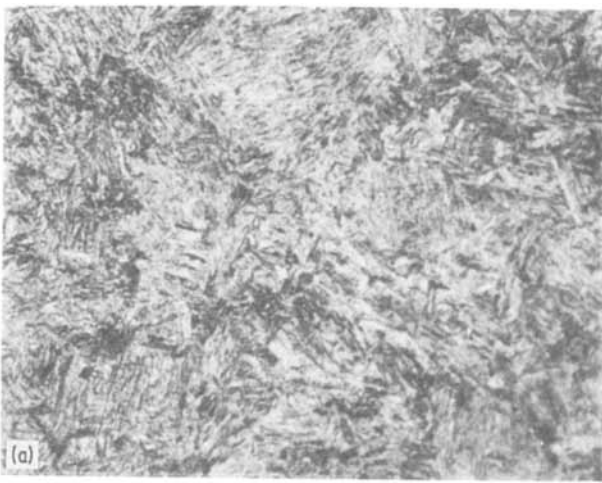
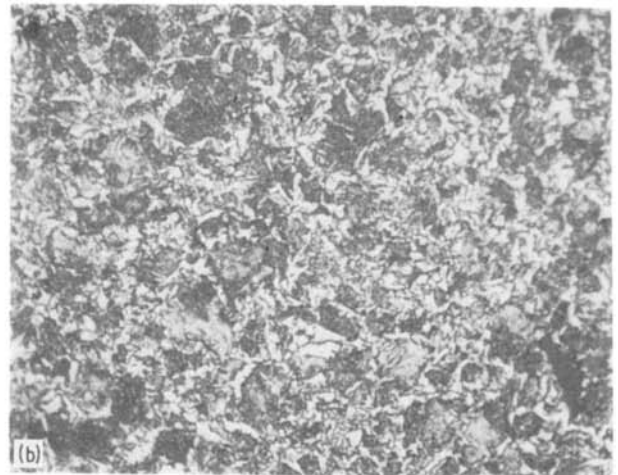
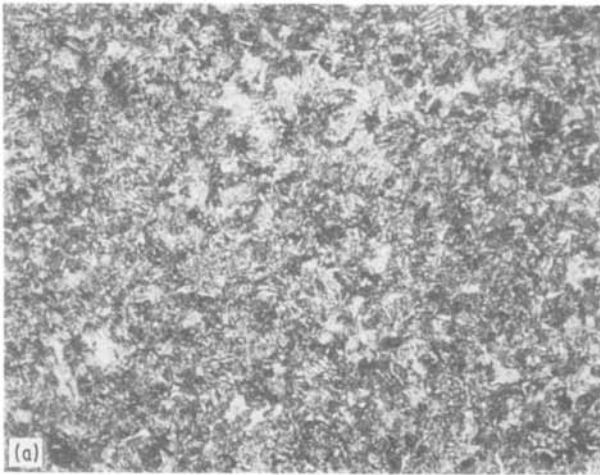

Figure 8 Microstructure of the 1045 steel sample quenched in SUNQUENCH 1032 at zero field,  $\times 546$ . (a) 1 mm from the surface, (b) near the centre.



**Figure 9** Microstructure of the 1045 steel sample quenched in SUNQUENCH 1032 with an electric field,  $\times 546$ . (a) 1 mm from the surface (b) near the centre.

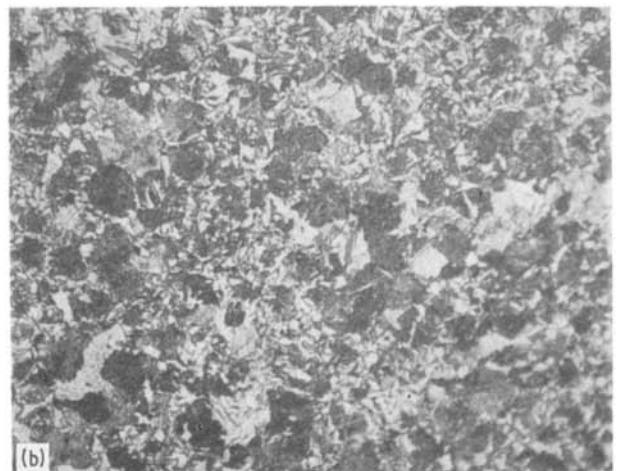
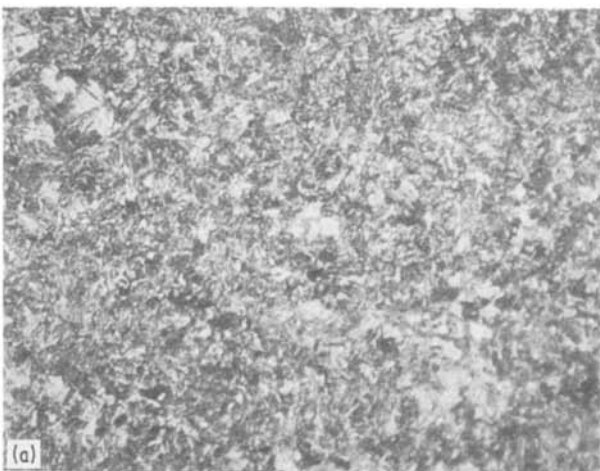

**Figure 10** Microstructure of the 1035 steel sample quenched in DURO AW 16 at zero field,  $\times 546$ . (a) 1 mm from the surface, (b) near the centre.

controlled quenching process. In such a process, the time-varying electric field strength required to give the optimum cooling rate during the quench first would be calculated. This time-varying electric field then would be applied by programming a microprocessor to control the output of the voltage source.

## 6. Suggested directions for further work

The electric-field enhanced quenching experiment described in this report is preliminary. To develop this technique to a practical industrial process, more extensive experiments are needed to determine quantitatively



**Figure 11** Microstructure of the 1035 steel sample quenched in DURO AW 16 with an electric field,  $\times 546$ . (a) 1 mm from the surface, (b) near the centre.

the effect of the electric field strength, the effect of the nature of the quenching liquid (particularly the dielectric constant), and the effect of alloy-controlled hardenability on the quench quality. To obtain a better understanding of the mechanism of this field-enhanced quenching process, further experiments should be done to provide data on the electric field effect on the transient temperature distribution (using thermocouples) of the sample during the quench. Furthermore, it is desirable to obtain experimental data using other geometries of the electric field. One convenient alternate field geometry can be obtained by using a rectangular quench bath with two flat plate electrodes mounted at two opposite inner walls of the bath. This produces a uniform parallel electric field in the quenching liquid.

## 7. Conclusions

The electric field effect on the heat transfer rate during the quenching process has been reviewed, and the improvement in the hardness of quenched samples through using an electric field has been demonstrated experimentally. The experimental results show that an

electric field could increase the effective hardenability of a steel industrial quenching process.

## Acknowledgement

We are grateful to Joe Stravinkas of Bethlehem Steel Corporation and Burt Sauvageot of East Carolina Heat Treatment Service for providing materials used in our experiment.

## References

1. F. SEDGWICK, US Patent No. 400366, March 26 (1889).
2. A. A. SKIMBOV, I. A. KOZUXAR, J. A. SCEGLOV and A. S. LYMAR, *Elektronnaya Obrabotka Materialov* (1983) p. 42. (in Russian, English translation by Edna Andrews).
3. M. MARKELS and R. L. DURFEE, *Amer. Inst. Chem. Engrs J.* **10** (1964) 106.
4. K. J. CHENG, PhD dissertation, Duke University (1986).
5. *Idem, ibid.* **11** (1965) 716.
6. A. G. ZHORZHOLIANI and I. G. SHEKRILADZE, *Heat Transfer Sov. Res.* **4** (1972) 81.
7. T. B. JONES, *Adv. Heat Transfer* **14** (1978) 107.

*Received 20 January  
and accepted 10 April 1986*